

18" Recessed Handle Special Application

300 Series – White SPE53U52UC



SPE53U52UC
White

Also available in:
Stainless Steel SPE53U55UC
Black SPE53U56UC

Bosch dishwashers incorporate 18 unique sound-reducing technologies, to make Bosch the quietest dishwasher brand in the US.

Features & Benefits

46 dBA: Quietest dishwasher brand.

Water softener ensures optimally spot-free and shiny dishes.

RackMatic® offers 3 height levels, for 9 possible rack positions.

AquaStop® Plus 4-Part leak protection prevents water damage 24/7.

24h Delay Start Timer lets you run your dishwasher at off-peak times.

General Properties	
Number of wash cycles	4
Number of options	4
dBA	46
Third rack	No
Rack adjustability	RackMatic®
Tub material	Stainless steel
Control type	Buttons
Concealed heating element	Yes
Leak protection system	24/7 AquaStop® Plus
Water softener	Yes
Five-level wash	Yes
ChildLock	Yes
Special features	24h delay start timer

Efficiency	
Water usage per cycle	3.0
Energy efficiency class	Tier 1
ENERGY STAR® qualified	Yes
Total annual energy consumption (kWh)	259 kWh
Total annual water consumption (g)	645

Capacity	
Number of place settings	9



Technical Details	
Watts (W)	1300 W
Current (A)	12 Amps
Volts (V)	120 V
Frequency (Hz)	60 Hz
Power cord length	68 7/8"
Minimum water pressure (lb/sin)	7
Length inlet hose (in)	65"
Length outlet hose (in)	80 5/8"

Dimensions & Weight	
Overall appliance dimensions (HxWxD) (in)	32 1/16" x 17 5/8" x 22 9/16"
Required cutout size (HxWxD) (in)	32 1/8" x 17 3/4" x 24"
Adjustable feet	Yes
Net weight (lbs)	72 lbs

Accessories—Optional	
Dishwasher Softener Salt (4.4 lbs)	SGZ9091UC
Dishwasher Supply and Drainage Hose Extension 76 3/4"	SGZ1010UC
Dishwasher Accessory Kit	SMZ5000
Hinge for 4" Toekick Height Installation	SMZ5003



For help and assistance with Bosch accessories please visit: www.bosch-eshop.com/eshop/bosch/us or call 1-800-944-2904 Mon-Fri 5am to 6pm PST Sat 6am to 3pm PST

Notes: All height, width and depth dimensions are shown in inches. BSH reserves the absolute and unrestricted right to change product materials and specifications, at any time, without notice. Consult the product's installation instructions for final dimensional data and other details prior to making cutout. Applicable product warranty can be found in accompanying product literature or you may contact your account manager for further details.

Warranties: Bosch warrants that the Product is free from defects in materials and workmanship for a period of three hundred and sixty-five (365) days from the date of purchase. The foregoing timeline begins to run upon the date of purchase, and shall not be stalled, tolled, extended, or suspended, for any reason whatsoever. This Product is also warranted to be free from cosmetic defects in material and workmanship (such as scratches of stainless steel, paint/porcelain blemishes, chip, dents, or other damage to the finish) of the Product, for a period of thirty (30) days from the date of purchase or closing date for new construction. This cosmetic warranty excludes slight color variations due to inherent differences in painted and porcelain parts, as well as differences caused by kitchen lighting, product location, or other similar factors. This cosmetic warranty specifically excludes any display, floor, "As Is", or "B" stock appliances.

For more information on our entire line of products, go to www.bosch-home.com/us or call 1-800-944-2904

© BSH Home Appliances Corporation. All rights reserved. Bosch is a registered trademark of Robert Bosch GmbH.

18" Recessed Handle Special Application

300 Series – White SPE53U52UC



Installation Details

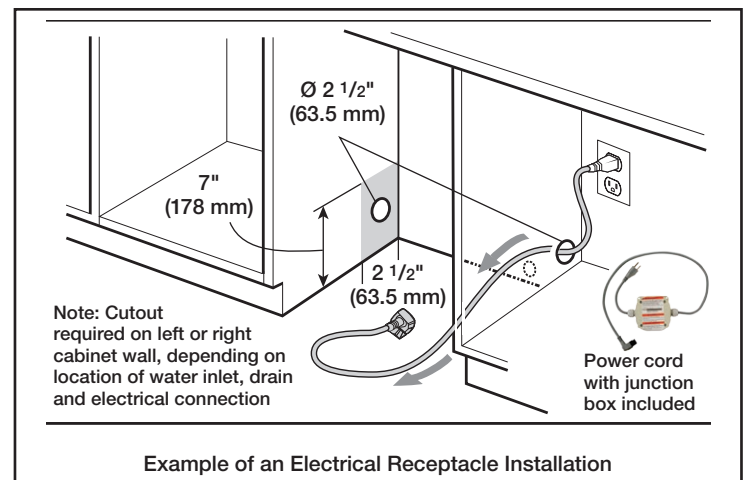
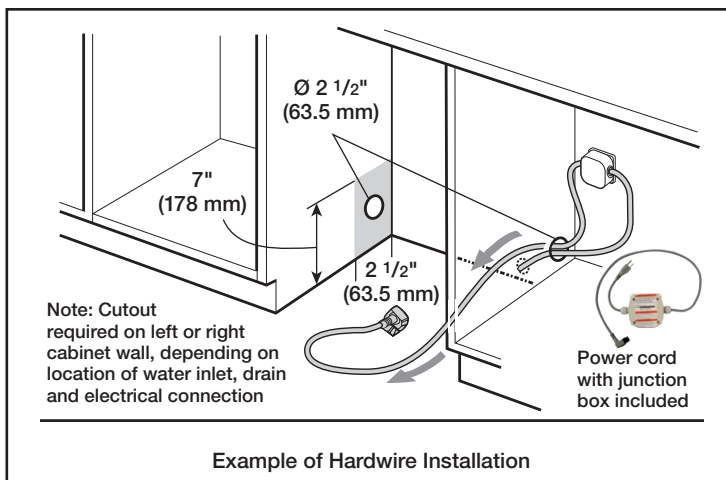
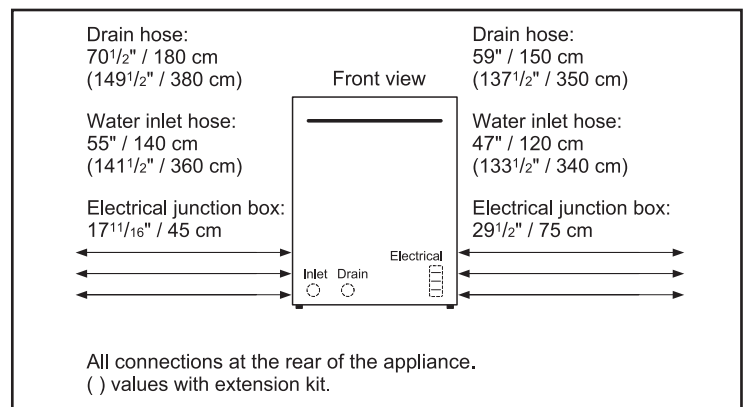
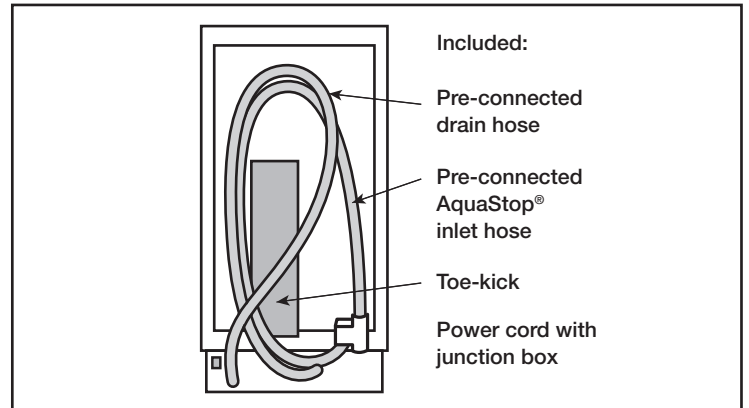
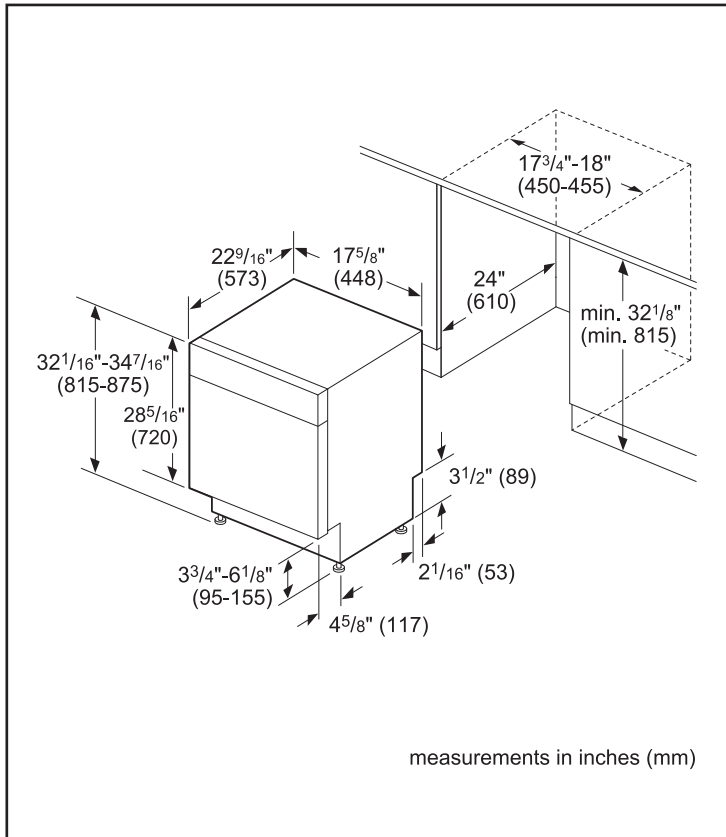

For help and assistance with Bosch accessories please visit: www.bosch-eshop.com/eshop/bosch/us or call 1-800-944-2904 Mon-Fri 5am to 6pm PST Sat 6am to 3pm PST

Notes: All height, width and depth dimensions are shown in inches. BSH reserves the absolute and unrestricted right to change product materials and specifications, at any time, without notice. Consult the product's installation instructions for final dimensional data and other details prior to making cutout. Applicable product warranty can be found in accompanying product literature or you may contact your account manager for further details.

Warranties: Bosch warrants that the Product is free from defects in materials and workmanship for a period of three hundred and sixty-five (365) days from the date of purchase. The foregoing timeline begins to run upon the date of purchase, and shall not be stalled, tolled, extended, or suspended, for any reason whatsoever. This Product is also warranted to be free from cosmetic defects in material and workmanship (such as scratches of stainless steel, paint/porcelain blemishes, chip, dents, or other damage to the finish) of the Product, for a period of thirty (30) days from the date of purchase or closing date for new construction. This cosmetic warranty excludes slight color variations due to inherent differences in painted and porcelain parts, as well as differences caused by kitchen lighting, product location, or other similar factors. This cosmetic warranty specifically excludes any display, floor, "As Is", or "B" stock appliances.

For more information on our entire line of products, go to www.bosch-home.com/us or call 1-800-944-2904

© BSH Home Appliances Corporation. All rights reserved. Bosch is a registered trademark of Robert Bosch GmbH.

09/15

18" Recessed Handle Special Application

300 Series – White SPE53U52UC



Installation Details

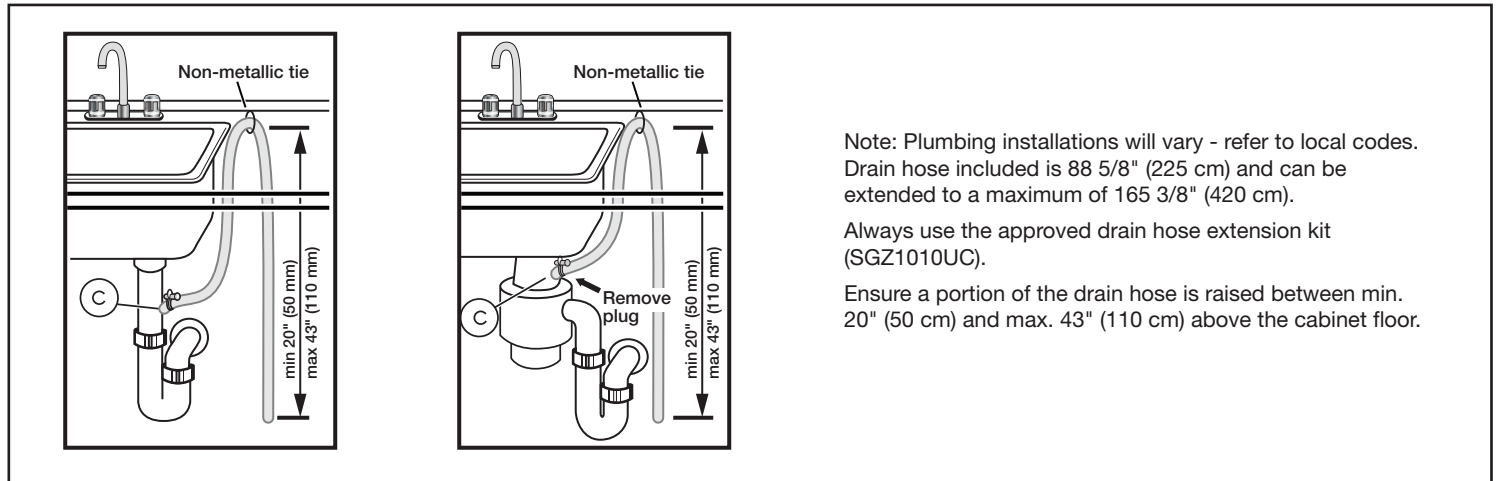

For help and assistance with Bosch accessories please visit: www.bosch-eshop.com/eshop/bosch/us or call 1-800-944-2904 Mon-Fri 5am to 6pm PST Sat 6am to 3pm PST

Notes: All height, width and depth dimensions are shown in inches. BSH reserves the absolute and unrestricted right to change product materials and specifications, at any time, without notice. Consult the product's installation instructions for final dimensional data and other details prior to making cutout. Applicable product warranty can be found in accompanying product literature or you may contact your account manager for further details.

Warranties: Bosch warrants that the Product is free from defects in materials and workmanship for a period of three hundred and sixty-five (365) days from the date of purchase. The foregoing timeline begins to run upon the date of purchase, and shall not be stalled, tolled, extended, or suspended, for any reason whatsoever. This Product is also warranted to be free from cosmetic defects in material and workmanship (such as scratches of stainless steel, paint/porcelain blemishes, chip, dents, or other damage to the finish) of the Product, for a period of thirty (30) days from the date of purchase or closing date for new construction. This cosmetic warranty excludes slight color variations due to inherent differences in painted and porcelain parts, as well as differences caused by kitchen lighting, product location, or other similar factors. This cosmetic warranty specifically excludes any display, floor, "As Is", or "B" stock appliances.

For more information on our entire line of products, go to www.bosch-home.com/us or call 1-800-944-2904

© BSH Home Appliances Corporation. All rights reserved. Bosch is a registered trademark of Robert Bosch GmbH.

09/15